

Declared qualities stated

Harmonised technical specification		✓ EN 16510	✓ DIN+	DIBt	EN 13240
		✓ Ecodesign	✓ BlmSchV2	✓ 15a B-VG 2015	EN 13229
Classification of appliance		Type BE			
		Nominal heat output (nom)	Part load heat output (part)		
Energy efficiency	$\eta_{nom} \eta_{part}$	81,1	---		%
Seasonal space heating energy efficiency at nominal heat output	$\eta_{Snom} \eta_{Spart}$	---	---		%
Energy Efficiency Index	EEI	107,6			
Energy label		A+			
Fuel		Wood logs			
Fuel length		200-330			mm
Average fuel consumption		1,73	---		kg/h
Allowed fuel dose		2,3			kg/h
Fuel supply interval		1 hour			
Amount of combustion air		21,9			m ³ /h
Nominal heat output	$P_{nom} P_{part}$	5,8	---		kW
Hot-water exchanger nominal heat output	$P_{Wnom} P_{Wpart}$	---	---		kW
Maximum water operating pressure	P_W	---			bar
Dry flue gas mass flow rate	$\Phi_{f,g nom} \Phi_{f,g part}$	6,9	---		g/s
Average flue gas temperature		259	---		°C
Flue gas outlet temperature		311	---		°C
Flue draught		12			Pa
Chimney temperature class		T400			
Connection to the common chimney		Yes			
Storage of fuel in the wood shed area		No			
Maximum warming of the wood in the wood shed		---			°C
Dust O ₂ = 13 %	$PM_{nom} PM_{part}$	18	---		mg/Nm ³
Emissions of gases of sobustion (CO in the flue gases at O ₂ = 13 %)	$CO_{nom} CO_{part}$	0,0994 1243	---		% mg/Nm ³
OGC O ₂ = 13 %	$OGC_{nom} OGC_{part}$	39	---		mg/Nm ³
NOx O ₂ = 13 %	$NO_{xnom} NO_{xpart}$	114	---		mg/Nm ³
Automatic regulation unit of burning		---	---		
Electricity consumption in standby mode	e_{lsb}	---			kW
Electricity consumption	$e_{lmax} e_{lmin}$	---	---		kW
Standing air loss	V_h	---			m ³ /h
Intermittent operation Continuous operation	INT CON	INT			

Basic technical data

Principal dimensions (Height Width Length)	H W L	1697 600 451	mm
Combustion chamber dimensions	H W L	466 416 215	mm
Fireplace door dimensions	H W L	480 601 46	mm
Axis height of the rear (side) outlet		1456	mm
Volume of hot-water exchanger		---	l
Flue diameter		150	mm
Diameter of flue throat	d_{out}	150	mm
Diameter of external air connection		125	mm
Maximum length (pipe) of external air intake		5000	mm
Weight	m	206	kg
Load bearing capacity	m_{chim}	200	kg

Heat capacity

minimum size of the room of appliance installation

Insulation of the house – very good (20 W/m ³) e.g. new, insulated house / permanently inhabited	216	m ³
Insulation of the house – good (22,5 W/m ³)	192	m ³
Insulation of the house – middle (32 W/m ³)	135	m ³
Insulation of the house – bad (45 W/m ³)	96	m ³
Insulation of the house – very bad (50 W/m ³) e.g. old, uninsulated house / cottage / chalet	86	m ³

Distances from flammable materials

with un-insulated flue pipe (provided on the product label)

Note

Back	d_R	80	mm
Front	d_P	900	mm
Front to the floor	d_F	450	mm
Side	d_S	---	mm
Side with glass	d_{S1}	450	mm
Side – niche	d_{S2}	---	mm
Side – location 45°	d_{S3}	---	mm
Side radiation	d_L	450	mm
From the floor	d_B	40	mm
From the ceiling	d_C	750	mm

Distances from flammable materials with insulated flue pipe **

Back	d_R	0	mm
Side	d_S	450	mm

Distances from nonflammable materials

Back	d_{Rnon}	0	mm
Side	d_{Snon}	450	mm
Side – niche	d_{S2non}	---	mm

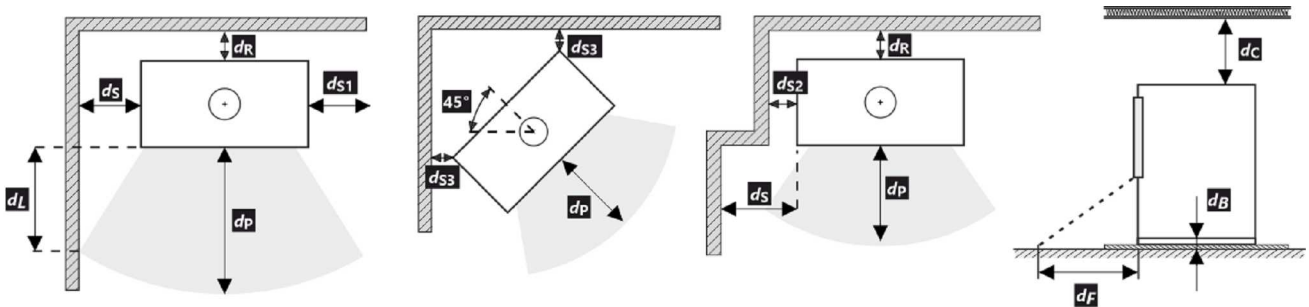

* All local regulations, including regulations relating to national and European standards, must be observed during the installation and operation of the product.

** The distance assumes the use of an insulated flue pipe with a minimum insulation thickness of 25 mm up to the product.

Distance from flammable (nonflammable) materials – rear flue connection

Back	d_R	80	mm
Side	d_S	---	mm

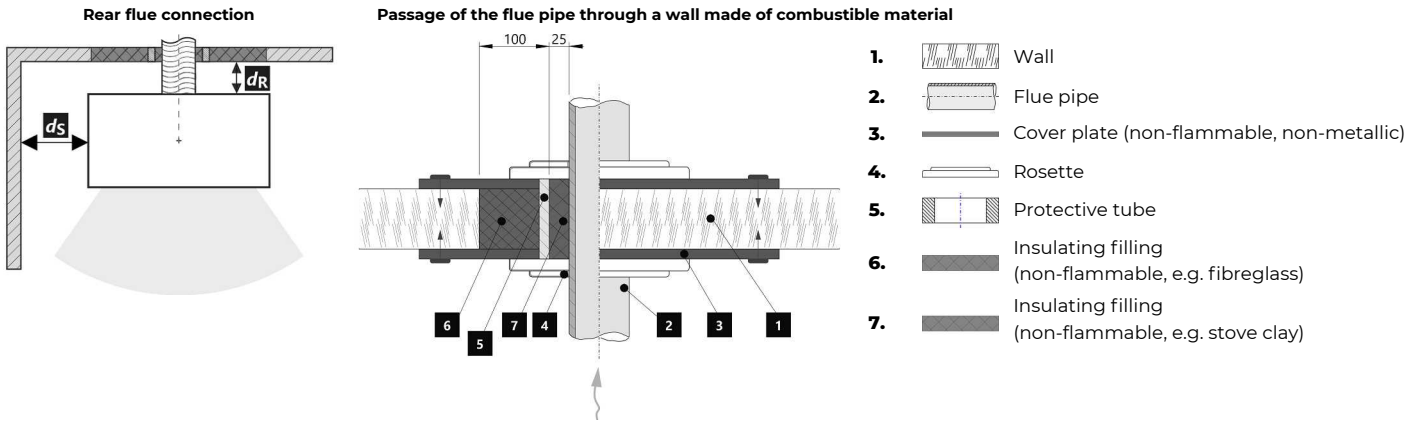

Distance from flammable (nonflammable) materials – rear flue connection (insulated)

Back	d_R	0	mm
Side	d_S	450	mm

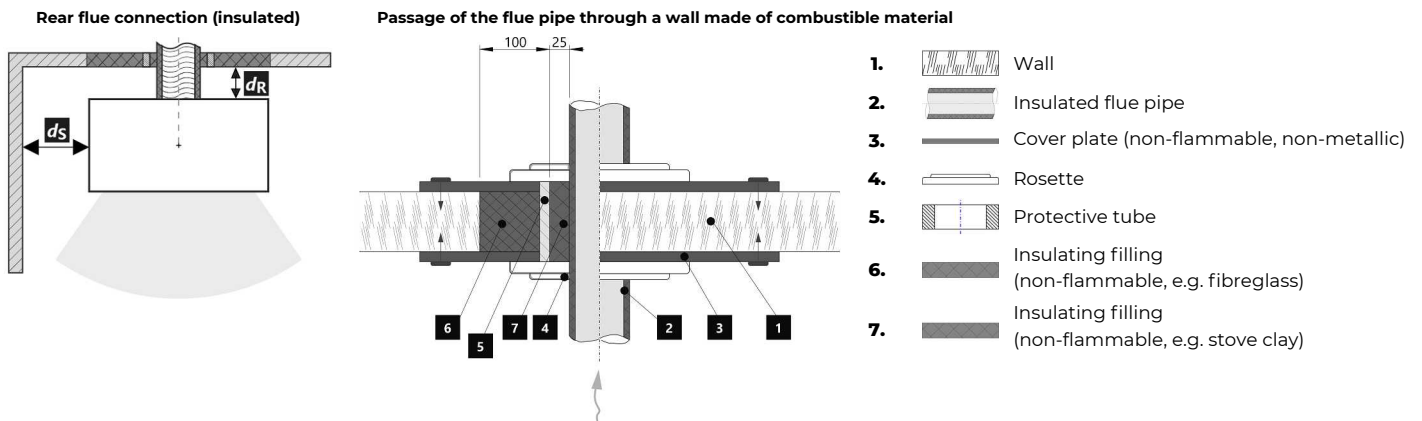

Deklarierte Produkteigenschaften

Harmonisierte technische Spezifikation		✓ EN 16510	✓ DIN+	DIBt	EN 13240
		✓ Ecodesign	✓ BlmSchV2	✓ 15a B-VG 2015	EN 13229
Produktklassifizierung	Type BE				
		Nennwärmeleistung (nom)	Teillastwärmeleistung (part)		
Energiewirkungsgrad	$\eta_{nom} \eta_{part}$	81,1	---		%
Raumheizungs-Jahresnutzungsgrad	$\eta_{Snom} \eta_{Spart}$	---	---		%
Energieeffizienzindex	EEL	107,6			
Energielabel		A+			
Brennstoff		Scheitholz			
Brennstofflänge		200-330			mm
Durchschnittlicher Brennstoffverbrauch		1,73	---		kg/h
Zulässiger Brennstoffverbrauch		2,3			kg/h
Brennstofflieferintervall		1 Stunde			
Verbrennungsluftmenge		21,9			m ³ /h
Nennwärmeleistung	$P_{nom} P_{part}$	5,8	---		kW
Wärmetauscherleistung	$P_{Wnom} P_{Wpart}$	---	---		kW
Maximaler Wasserbetriebsdruck	p_W	---			bar
Rauchgasmassenstrom (trocken)	$\Phi_{f,g nom} \Phi_{f,g part}$	6,9	---		g/s
Durchschnittliche Abgastemperatur		259	---		°C
Rauchgasaustrittstemperatur		311	---		°C
Förderdruck		12			Pa
Temperaturklasse		T400			
Mehrfachbelegung		Ja			
Lagerung von Brennstoff im Holzfach		Nein			
Maximale Erwärmung des Holzes im Holzfach		---			°C
Feinstaub O ₂ = 13 %	$PM_{nom} PM_{part}$	18	---		mg/Nm ³
Abgasemission (CO in den Abgasen bei O ₂ = 13 %)	$CO_{nom} CO_{part}$	0,0994 1243	---	---	% mg/Nm ³
OGC O ₂ = 13 %	$OGC_{nom} OGC_{part}$	39	---		mg/Nm ³
NO _x O ₂ = 13 %	$NO_{xnom} NO_{xpart}$	114	---		mg/Nm ³
Automatische Abbrandsteuerung		---	---		
Stromverbrauch im Bereitschaftszustand	e_{lSB}	---			kW
Stromverbrauch	$e_{lmax} e_{lmin}$	---	---		kW
Ständiger Luftverlust	V_h	---			m ³ /h
Intervallbetrieb Dauerbetrieb	INT CON	INT			

Technische Grunddaten

Hauptabmessungen (Höhe Breite Tiefe)	H W L	1697 600 451		mm
Abmessungen der Brennkammer (Höhe Breite Tiefe)	H W L	466 416 215		mm
Abmessungen der Feuerraumtür (Höhe Breite Tiefe)	H W L	480 601 46		mm
Achshöhe hinterer (seitlichen) Rauchrohanschluss		1456		mm
Volumen Wärmetauscher		---		l
Rauchrohrdurchmesser		150		mm
Abgasstutzen	d_{out}	150		mm
Durchmesser zentrale Luftzufuhr		125		mm
Maximale Länge (Rohrleitung) der zentralen Luftzufuhr		5000		mm
Gewicht	m	206		kg
Tragfähigkeit	m_{chim}	200		kg

Heizleistung (Brennwert)

mindestraumgröße für die Installation des Produkts

Wärmedämmung des Hauses – sehr gut (20 W/m ³)	z.B. neues, isoliertes Haus / ständig bewohnt	216	m ³
Wärmedämmung des Hauses – gut (22,5 W/m ³)		192	m ³
Wärmedämmung des Hauses – mittel (32 W/m ³)		135	m ³
Wärmedämmung des Hauses – schlecht (45 W/m ³)		96	m ³
Wärmedämmung des Hauses – sehr schlecht (50 W/m ³)	z.B. altes, ungedämmtes Haus / Hütte / Chalet	86	m ³

Abstand zu brennbaren Materialien

mit unisoliertem Rauchrohr (auf dem Typenschild angegeben)

Bemerkung

Rückwand	d_R	80	mm
Strahlungsbereich	d_P	900	mm
Strahlungsbereich zum Boden	d_F	450	mm
Seitenwände	d_S	---	mm
Seite mit Glas	d_{S1}	450	mm
Seite – Nische	d_{S2}	---	mm
Seite – Ausrichtung 45°	d_{S3}	---	mm
Seitliche Strahlung	d_L	450	mm
Von dem Boden	d_B	40	mm
Von der Decke	d_C	750	mm

Abstand zu brennbaren Materialien mit isoliertem Rauchrohr **

Rückwand	d_R	0	mm
Seitenwände	d_S	450	mm

Abstand zu nicht brennbaren Materialien

Rückwand	d_{Rnon}	0	mm
Seitenwände	d_{Snon}	450	mm
Seite – Nische	d_{S2non}	---	mm

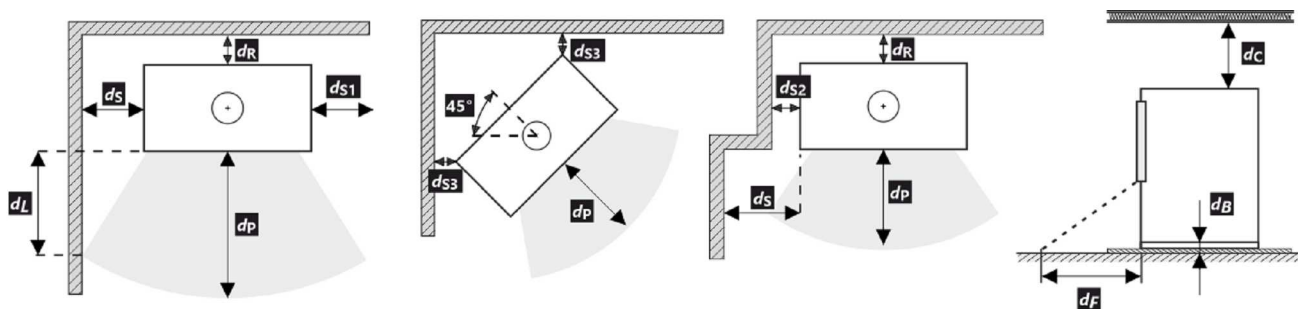

- * Bei der Installation und dem Betrieb des Ofens sind alle örtlichen Vorschriften sowie nationale und europäische Normen zu beachten.
- ** Der Abstand setzt die Verwendung eines isolierten Rauchrohrs mit einer Mindestdämmstärke von 25 mm bis zum Produkt voraus.

Abstand zu brennbaren (nicht brennbaren) Materialien – hinterer Rauchrohranschluss

Rückwand	d_R	80	mm
Seitenwände	d_S	---	mm

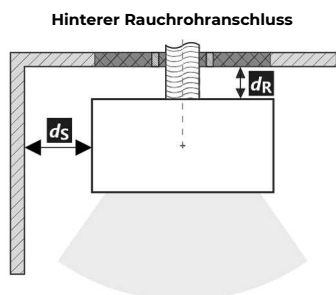
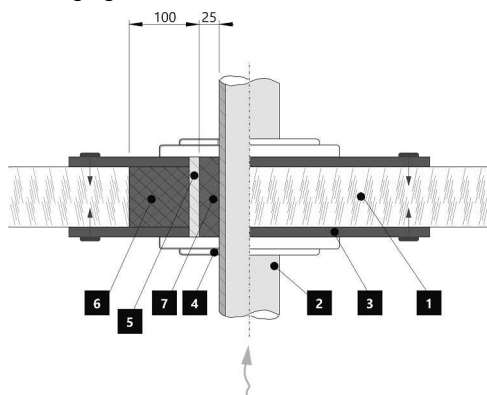
Durchgang des Rauchrohrs durch eine Wand aus brennbarem Material

1. Wand
2. Rauchrohr
3. Abdeckplatte (nicht brennbar, kein metallisch)
4. Rosette
5. Schutzrohr
6. Isolierung (nicht entflammbar, z. B. Glasfaser)
7. Isolierung (nicht brennbar, z. B. Ofenlehm)

Abstand zu brennbaren (nicht brennbaren) Materialien – hinterer Rauchrohranschluss (isoliert)

Rückwand	d_R	0	mm
Seitenwände	d_S	450	mm

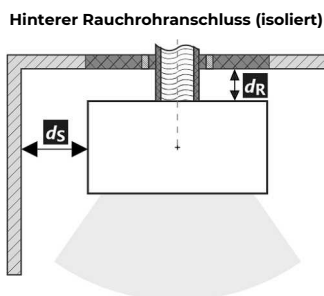
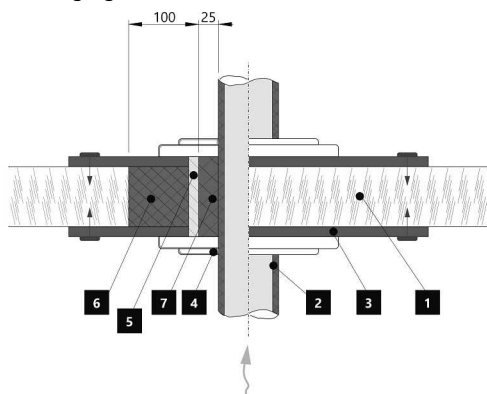
Durchgang des Rauchrohrs durch eine Wand aus brennbarem Material

1. Wand
2. Isoliertes Rauchrohr
3. Abdeckplatte (nicht brennbar, kein metallisch)
4. Rosette
5. Schutzrohr
6. Isolierung (nicht entflammbar, z. B. Glasfaser)
7. Isolierung (nicht brennbar, z. B. Ofenlehm)

Caractéristiques déclarées du produit

Norme(s) Européennes		✓ EN 16510	✓ DIN+	DIBt	EN 13240
		✓ Ecodesign	✓ BlmSchV2	✓ 15a B-VG 2015	EN 13229
Classification de l'appareil		Type BE			
		Puissance thermique nominale (nom)	Puissance thermique partielle (part)		
Efficacité énergétique	$\eta_{nom} \eta_{part}$	81,1	---		%
Efficacité énergétique saisonnier à la puissance thermique nominale de l'appareil	$\eta_{s,nom} \eta_{s,part}$	---	---		%
Indice d'efficacité énergétique EEI	EEI	107,6			
Label énergétique		A+			
Combustible		Bûches			
Longueur recommandée de bûches		200-330			
Consommation moyenne de combustible		1,73	---		kg/h
Charge en bois autorisé		2,3			
Intervalle entre les chargements de combustible		1 heure			
Débit massique des fumées		21,9			
Puissance thermique nominale	$P_{nom} P_{part}$	5,8	---		kW
Puissance thermique nominale de l'échangeur	$P_{W,nom} P_{W,part}$	---	---		kW
Pression d'eau maximale	P_W	---			
Débit massique des gaz de combustion secs	$\Phi_{f,g,nom} \Phi_{f,g,part}$	6,9	---		g/s
Température moyenne des résidus de combustion		259	---		°C
Température de sortie des gaz de combustion		311	---		°C
Tirage de conduit de fumée		12			
Classe de température		T400			
Raccordement à une cheminée collective		Oui			
Stockage du combustible dans range bûches		Non			
Réchauffement maximal du bois dans range bûches		---			
Poussière O ₂ = 13 %	$PM_{nom} PM_{part}$	18	---		mg/Nm ³
Résidus de combustion émis (CO dans les résidus de combustion pour O ₂ = 13 %)	$CO_{nom} CO_{part}$	0,0994 1243	---		% mg/Nm ³
OGC O ₂ = 13 %	$OGC_{nom} OGC_{part}$	39	---		mg/Nm ³
NOx O ₂ = 13 %	$NO_{x,nom} NO_{x,part}$	114	---		mg/Nm ³
Régulation automatique de la combustion		---			
Consommation d'énergie en mode veille	$e_{l,SB}$	---			
Consommation d'électricité	$e_{l,max} e_{l,min}$	---	---		kW
Standing air loss	V_h	---			
Fonctionnement par intermittence Service ininterrompu	INT CON	INT			

Données techniques de base

Dimensions principales (Hauteur Largeur Profondeur)	H W L	1697 600 451	mm
Dimensions de la chambre de combustion (Hauteur Largeur Profondeur)	H W L	466 416 215	mm
Dimensions de la porte (Hauteur Largeur Profondeur)	H W L	480 601 46	mm
Hauteur de l'axe de la sortie arrière (latérale)		1456	mm
Volume de l'échangeur de chaleur		---	l
Diamètre du conduit de fumée		150	mm
Diamètre de buse d'air de combustion	d_{out}	150	mm
Diamètre de l'arrivée d'air centrale		125	mm
Longueur maximale (tuyau) d'arrivée d'air centrale		5000	mm
Poids	m	206	kg
Capacité de charge	m_{chim}	200	kg

Capacité thermique (Pouvoir calorifique)

taille minimale de la pièce où est installé l'appareil

Isolation de la maison – très bon (20 W/m ³)	par exemple, maison neuve et isolée / habitée en permanence	216	m ³
Isolation de la maison – bon (22,5 W/m ³)		192	m ³
Isolation de la maison – moyen (32 W/m ³)		135	m ³
Isolation de la maison – mauvais (45 W/m ³)		96	m ³
Isolation de la maison – très mauvais (50 W/m ³)	par exemple une vieille maison / chalet / chalet non isolé	86	m ³

Distance par rapport aux matériaux combustibles

pour un conduit de fum. non isolé (conform. aux la plaque signalétique)

Note

Arrière	d_R	80	mm
Avant	d_P	900	mm
Avant (par rapport au sol)	d_F	450	mm
Latéral	d_S	---	mm
Latéral avec vitre	d_{S1}	450	mm
Latéral – niche	d_{S2}	---	mm
Latéral – emplacement 45°	d_{S3}	---	mm
Rayonnement latéral	d_L	450	mm
Depuis le sol	d_B	40	mm
Plafond	d_C	750	mm

Distance par rapport aux matériaux combustibles pour un conduit de fumée isolé **

Arrière	d_R	0	mm
Latéral	d_S	450	mm

Distance par rapport aux matériaux non combustibles

Arrière	d_{Rnon}	0	mm
Latéral	d_{Snon}	450	mm
Latéral – niche	d_{S2non}	---	mm

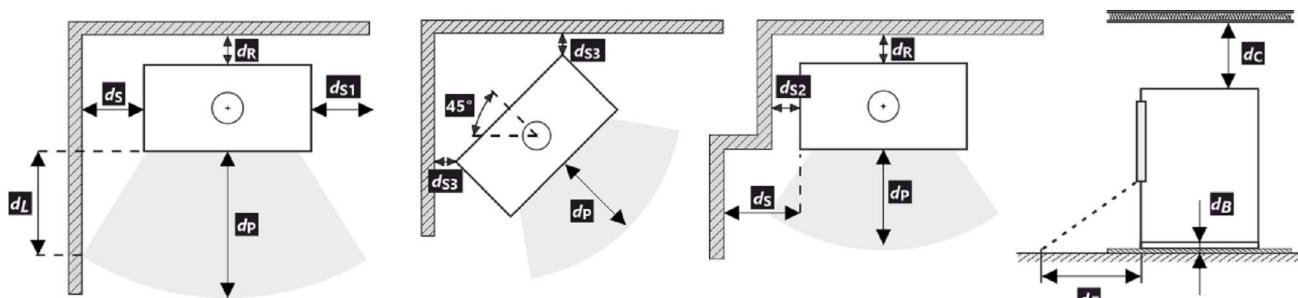

* Lors de l'installation et de l'utilisation du produit, toutes les réglementations locales doivent être respectées, y compris celles relatives aux normes nationales et européennes.

** La distance suppose l'utilisation d'un conduit de fumée isolé avec une épaisseur d'isolation minimale de 25 mm jusqu'au produit.

Distance par rapport aux matériaux combustibles (non combustibles) – Raccordement arrière du conduit de fumée

Arrière	d_R	80	mm
Latéral	d_S	---	mm

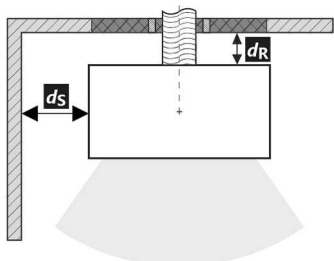
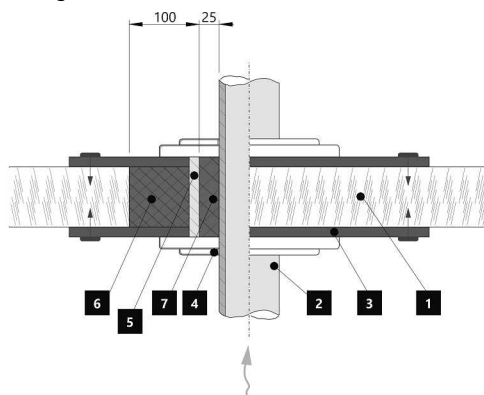
Raccordement arrière du conduit de fumée

Passage du conduit de fumée à travers un mur en matériau combustible

1. Mur
2. Conduit de fumée
3. Plaque de recouvrement (incombustibles, non métallique)
4. Rosage
5. Tuyau de protection
6. Remplissage isolant (incombustible, par exemple la fibre de verre)
7. Remplissage isolant (incombustible, par exemple l'argile des poêliers)

Distance par rapport aux matériaux combustibles (non combustibles) – Raccordement arrière du conduit de fumée (isolé)

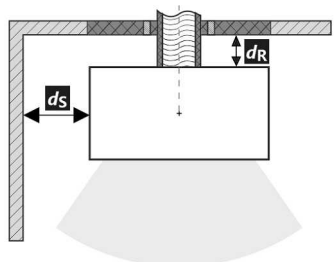
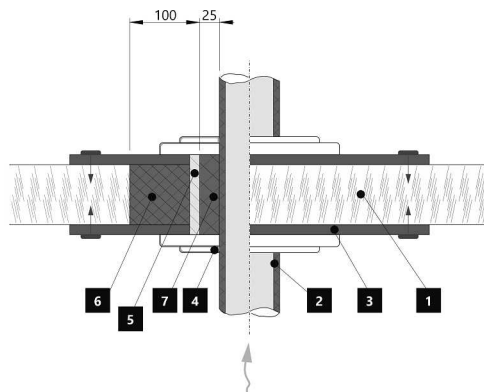
Arrière	d_R	0	mm
Latéral	d_S	450	mm

Raccordement arrière du conduit de fumée (isolé)

Passage du conduit de fumée à travers un mur en matériau combustible

1. Mur
2. Conduit de fumée isolé
3. Plaque de recouvrement (incombustibles, non métallique)
4. Rosage
5. Tuyau de protection
6. Remplissage isolant (incombustible, par exemple la fibre de verre)
7. Remplissage isolant (incombustible, par exemple l'argile des poêliers)

Proprietà dichiarate del prodotto

Specificazioni tecniche armonizzate		✓ EN 16510	✓ DIN+	DIBt	EN 13240
		✓ Ecodesign	✓ BlmSchV2	✓ 15a B-VG 2015	EN 13229
Classificazione del prodotto		Type BE			
		Potenza termica nominale (nom)	Potenza termica parziale (part)		
Efficienza energetica	$\eta_{nom} \eta_{part}$	81,1	---	%	
Efficienza energetica stagionale del riscaldamento d'ambiente	$\eta_{s,nom} \eta_{s,part}$	---	---	%	
Indice di efficienza prodotto	EEI	107,6			
Etichetta energetica		A+			
Combustibile		Legna			
Combustibile – lunghezza		200-330			mm
Consumo medio di combustibile		1,73	---	kg/h	
Dose ammessa di combustibile		2,3			kg/h
Intervallo di aggiunta di combustibile		1 ora			
Quantità di aria di combustione		21,9			m ³ /h
Potenza termica nominale	$P_{nom} P_{part}$	5,8	---	kW	
Potenza ter. nom. dello scambiatore di acqua calda	$P_{W,nom} P_{W,part}$	---	---	kW	
Ppressione massima di funzionamento dell'acqua	P_W	---			bar
Portata dei fumi di scarico secchi	$\Phi_{f,g,nom} \Phi_{f,g,part}$	6,9	---	g/s	
Temperatura media dei gas di scarico		259	---	°C	
Temperatura d'uscita dei gas di scarico		311	---	°C	
Tiro di esercizio		12			Pa
Classe di temperatura del camino		T400			
Collegamento al camino collettivo		Sì			
Stoccaggio del combustibile nell'area della stufa a legna		No			
Riscaldamento massimo della legna nella stufa a legna		---			°C
Polvere O ₂ = 13 %	$PM_{nom} PM_{part}$	18	---	mg/Nm ³	
Emissioni (CO nei gas comburenti all' O ₂ = 13 %)	$CO_{nom} CO_{part}$	0,0994 1243	---	%	
OGC O ₂ = 13 %	$OGC_{nom} OGC_{part}$	39	---	mg/Nm ³	
NOx O ₂ = 13 %	$NO_{x,nom} NO_{x,part}$	114	---	mg/Nm ³	
Controllo automatico della combustione		---	---		
Consumo di energia elettrica in modo stand-by	$e_{l,SB}$	---			kW
Consumo di energia elettrica	$e_{l,max} e_{l,min}$	---	---	kW	
Perdita d'aria in piedi	V_h	---			m ³ /h
Funzionamento intermittente Funzionamento continuo	INT CON	INT			

Dati tecnici di base

Dimensioni principali (Altezza Larghezza Profondità)	H W L	1697 600 451	mm
Dimensioni della camera di combustione (Altezza Larghezza Profondità)	H W L	466 416 215	mm
Dimensioni dello sportello del focolare (Alt. Larg. Prof.)	H W L	480 601 46	mm
Altezza dell'asse dell'uscita posteriore (laterale)		1456	mm
Volume dello scambiatore di acqua calda		---	l
Diametro del condotto fumario		150	mm
Diametro del gola della canna fumaria	d_{out}	150	mm
Diametro dell'afflusso centralizzato di aria		125	mm
Lunghezza mass. (tubo) di alimentazione centrale dell'aria		5000	mm
Peso	m	206	kg
Capacità di carico	m_{chim}	200	kg

Capacità termica (Potere calorifico)

dimensione minima del locale in cui è installato l'apparecchio

Isolamento della casa – molto buono (20 W/m ³)	ad esempio, casa nuova e isolata / abitata in modo permanente	216	m ³
Isolamento della casa – buono (22,5 W/m ³)		192	m ³
Isolamento della casa – medio (32 W/m ³)		135	m ³
Isolamento della casa – cattivo (45 W/m ³)		96	m ³
Isolamento della casa – molto male (50 W/m ³)	ad esempio, una vecchia casa / un cottage / uno chalet non isolato	86	m ³

Distanza di materiali infiammabili

con canna fumaria non isolata (indicato sull'etichetta di produzione)

Nota

Posteriore	d_R	80	mm
Anteriore	d_P	900	mm
Anteriore (rispetto al pavimento)	d_F	450	mm
Laterali	d_S	---	mm
Vetrata laterale	d_{S1}	450	mm
Laterali – nicchia	d_{S2}	---	mm
Laterali – posizione 45°	d_{S3}	---	mm
Radiazione laterale	d_L	450	mm
Dal pavimento	d_B	40	mm
Dal soffitto	d_C	750	mm

Distanza di materiali infiammabili con canna fumaria isolata **

Posteriore	d_R	0	mm
Laterali	d_S	450	mm

Distanza di materiali non infiammabili

Posteriore	d_{Rnon}	0	mm
Laterali	d_{Snon}	450	mm
Laterali – nicchia	d_{S2non}	---	mm

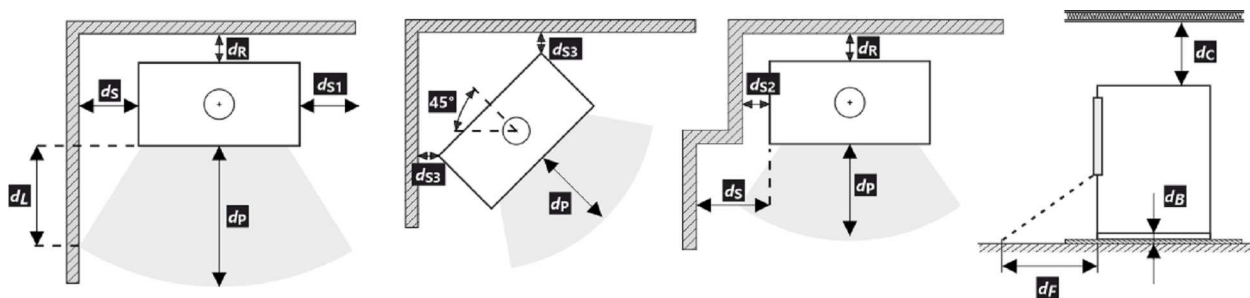

- * Durante il montaggio e l'uso del prodotto, devono essere rispettate tutte le normative locali, incluse le norme nazionali ed europee.
- ** La distanza presuppone l'utilizzo di una canna fumaria isolata con uno spessore minimo di isolamento di 25 mm fino al prodotto.

Distanza di materiali infiammabili (non infiammabili) – collegamento alla canna fumaria posteriore

Posteriore	d_R	80	mm
Laterali	d_S	---	mm

Collegamento alla canna fumaria posteriore

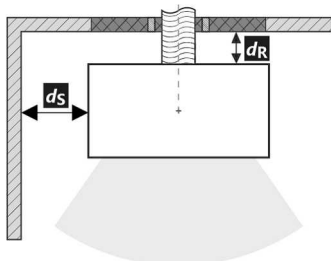

Passaggio della canna fumaria attraverso una parete in materiale combustibile

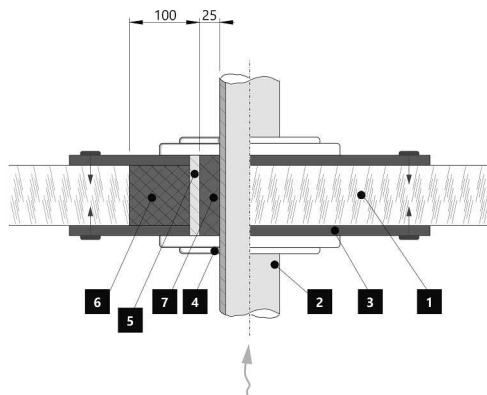

1. Muro
2. Canna fumaria
3. Piastra di copertura (non infiammabile, non metallica)
4. Rosetta
5. Tubo di protezione
6. Riempimento isolante (non infiammabile, ad es. Fibra di vetro)
7. Riempimento isolante (non infiammabile, ad esempio argilla per stufe)

Distanza di materiali infiammabili (non infiammabili) – collegamento alla canna fumaria posteriore (isolato)

Posteriore	d_R	0	mm
Laterali	d_S	450	mm

Raccordo della canna fumaria posteriore (isolato)

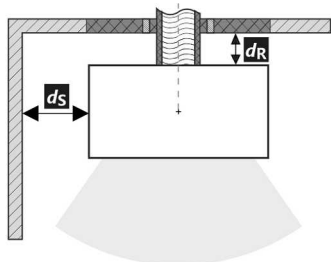

Passaggio della canna fumaria attraverso una parete in materiale combustibile

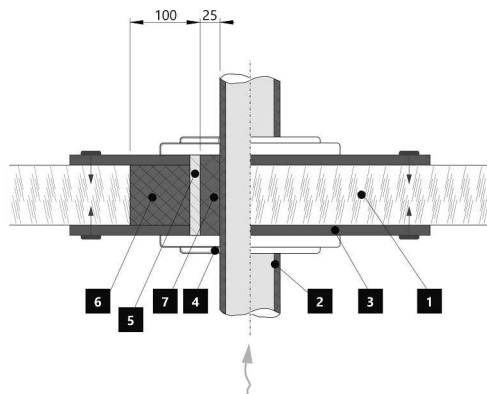

1. Muro
2. Canna fumaria isolata
3. Piastra di copertura (non infiammabile, non metallica)
4. Rosetta
5. Tubo di protezione
6. Riempimento isolante (non infiammabile, ad es. Fibra di vetro)
7. Riempimento isolante (non infiammabile, ad esempio argilla per stufe)

Deklaracija lastnosti

Harmonizirana tehnična specifikacija		✓ EN 16510	✓ DIN+	DIBt	EN 13240
		✓ Ecodesign	✓ BlmSchV2	✓ 15a B-VG 2015	EN 13229
Klasifikacija izdelka	Type BE				
		Nazivna toplotna moč (nom)	Toplotna moč pri delni obremenitvi (part)		
Energetska učinkovitost	$\eta_{nom} \eta_{part}$	81,1	---		%
Sezonska energetska učinkovitost pri ogrevanju prostorov	$\eta_{s,nom} \eta_{s,part}$	---	---		%
Indeks energetske učinkovitosti	EEI	107,6			
Energijska nalepka		A+			
Gorivo		Drva			
Priporočljiva dolžina goriva		200-330			mm
Povprečna poraba lesa		1,73	---		kg/h
Dovoljena količina lesa		2,3			kg/h
Interval dobave goriva za nazivno moč		1 ura			
Zahtevan zrak za izgorevanje		21,9			m ³ /h
Nazivna toplotna moč	$P_{nom} P_{part}$	5,8	---		kW
Izhod toplovodnega izmenjevalnika	$P_{W,nom} P_{W,part}$	---	---		kW
Maks. delovni tlak	p_W	---			bar
Masni pretok suhih dimnih plinov	$\Phi_{f,g,nom} \Phi_{f,g,part}$	6,9	---		g/s
Srednja temperatura plinov		259	---		°C
Temperatura izhodnih dimnih plinov		311	---		°C
Vlek dimnika		12			Pa
Temperaturni razred kamina		T400			
Priključek na skupni dimnik		Da			
Skladiščenje goriva v območju peči		Ne			
Maksimalno segrevanje lesa v območju peči na drva		---			°C
Prah O ₂ = 13 %	$PM_{nom} PM_{part}$	18	---		mg/Nm ³
Emisije izgorovalnih plinov (CO v dimne pline pri O ₂ = 13 %)	$CO_{nom} CO_{part}$	0,0994 1243	---		% mg/Nm ³
OGC O ₂ = 13 %	$OGC_{nom} OGC_{part}$	39	---		mg/Nm ³
NOx O ₂ = 13 %	$NO_{x,nom} NO_{x,part}$	114	---		mg/Nm ³
Avtomatska regulacija gorenja		---			
Poraba električne energije v stanju pripravljenosti	$e_{l,SB}$	---			kW
Poraba električne energije	$e_{l,max} e_{l,min}$	---			kW
Stalna izguba zraka	V_h	---			m ³ /h
Prekinjeno delovanje Neprekinjeno delovanje	INT CON	INT			

Osnovni tehnični podatki

Dimenzije (Višina Širina Globina)	H W L	1697 600 451		mm
Dimenzije zgorevalne komore (Višina Širina Globina)	H W L	466 416 215		mm
Dimenzije vrat peči (Višina Širina Globina)	H W L	480 601 46		mm
Višina osi zadnjega (stranskega) izpusta		1456		mm
Prostornina toplotnega izmenjevalnika		---		l
Premer priključka dimne cevi		150		mm
Premer dimne cevi	d_{out}	150		mm
Zunanji dovod zraka (ZDZ)		125		mm
Največja dolžina (cevi) zunanje dovoda zraka		5000		mm
Teža	m	206		kg
Nosilnost	m_{chim}	200		kg

Moč ogrevanja (Kurilna vrednost)

najmanjša velikost prostora primerne za vgradnjo naprave

Izolacija hiše – zelo dobro (20 W/m ³)	npr. nova, izolirana hiša / stalno naseljena	216	m ³
Izolacija hiše – dobro (22,5 W/m ³)		192	m ³
Izolacija hiše – srednja (32 W/m ³)		135	m ³
Izolacija hiše – slabo (45 W/m ³)		96	m ³
Izolacija hiše – zelo slabo (50 W/m ³)	npr. stara, neizolirana hiša / kočja / brunarica	86	m ³

Varna razdalja od vnetljivega materiala

z neizolirano dimovodno cevjo (navedeno na nalepki izdelka)

Opomba

Zadaj	d_R	80	mm
Spredaj	d_P	900	mm
Spredaj do tal	d_F	450	mm
Stran	d_S	---	mm
Stran s steklom	d_{S1}	450	mm
Stran – niša	d_{S2}	---	mm
Stran – postavitvev pod kotom 45°	d_{S3}	---	mm
Stransko sevanje	d_L	450	mm
Od tal	d_B	40	mm
Od stropa	d_C	750	mm

Varna razdalja od vnetljivega materiala z izolirano dimovodno cevjo **

Zadaj	d_R	0	mm
Stran	d_S	450	mm

Varna razdalja od negorljivega materiala

Zadaj	d_{Rnon}	0	mm
Stran	d_{Snon}	450	mm
Stran – niša	d_{S2non}	---	mm

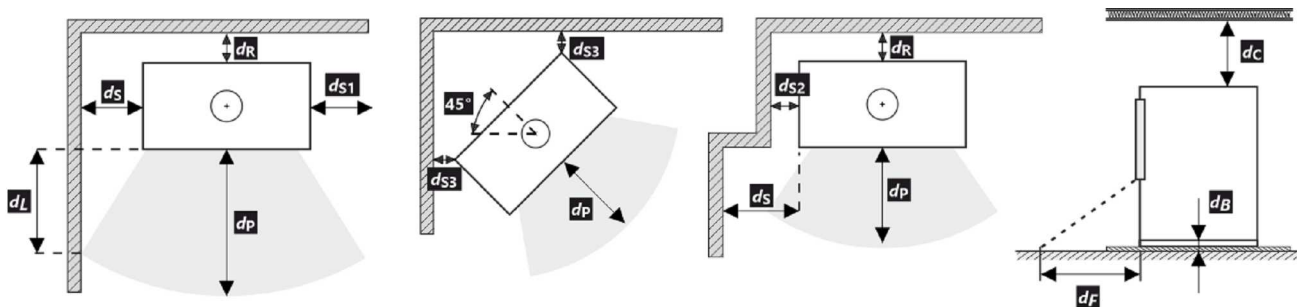

* Pri montaži in delovanju izdelka morajo biti upoštevani vsi lokalni predpisi, vključno predpisi, ki se nanašajo na lokalne in Evropske standarde.

** Razdalja predpostavlja uporabo izolirane dimovodne cevi z najmanjšo debelino izolacije 25 mm do izdelka.

Varna razdalja od vnetljivega (negorljivega) materiala – priključek iz hrbtnega dimnškega izpusta

Zadaj	d_R	80	mm
Stran	d_S	---	mm

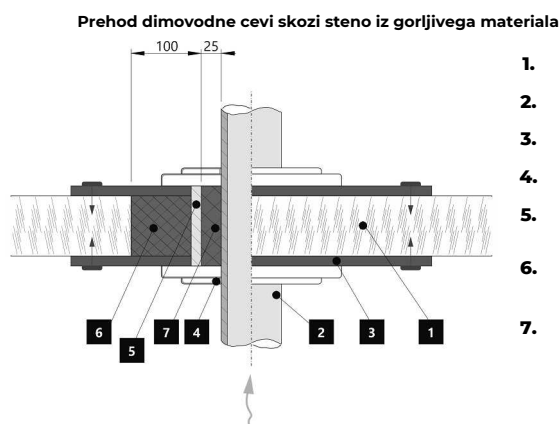
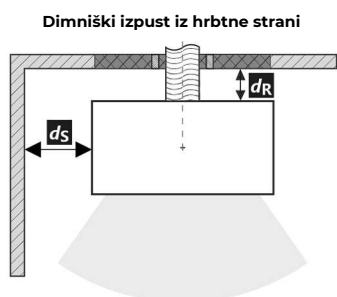

1. Stena
2. Dimne cevi
3. Pokrivna plošča (negorljiva, nekovinska)
4. Rozeta
5. Zaščitna cev
6. Izolacijsko polnilo (nevnetljivo, npr. steklena vlakna)
7. Izolacijsko polnilo (nevnetljivo, npr. glinena peči)

Varna razdalja od vnetljivega (negorljivega) materiala – priključek iz hrbtnega dimnškega izpusta (izoliran)

Zadaj	d_R	0	mm
Stran	d_S	450	mm

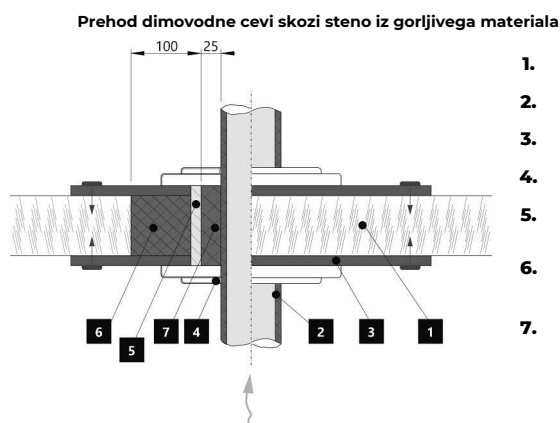
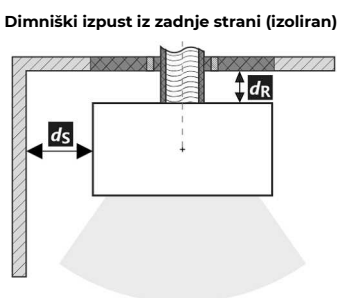

1. Stena
2. Izolirana dimovodna cev
3. Pokrivna plošča (negorljiva, nekovinska)
4. Rozeta
5. Zaščitna cev
6. Izolacijsko polnilo (nevnetljivo, npr. steklena vlakna)
7. Izolacijsko polnilo (nevnetljivo, npr. glinena peči)